

FLANGE X FLANGE

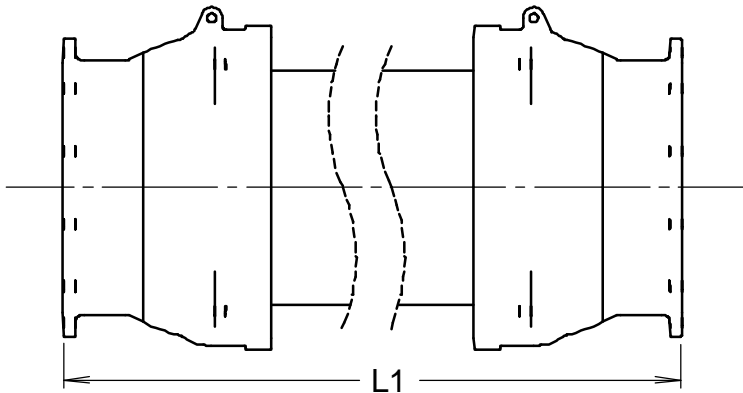

MJ X MJ

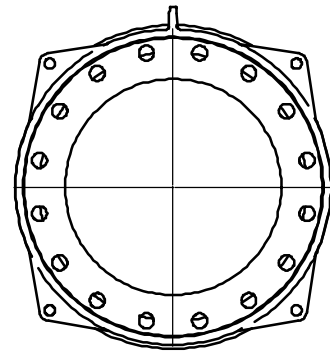
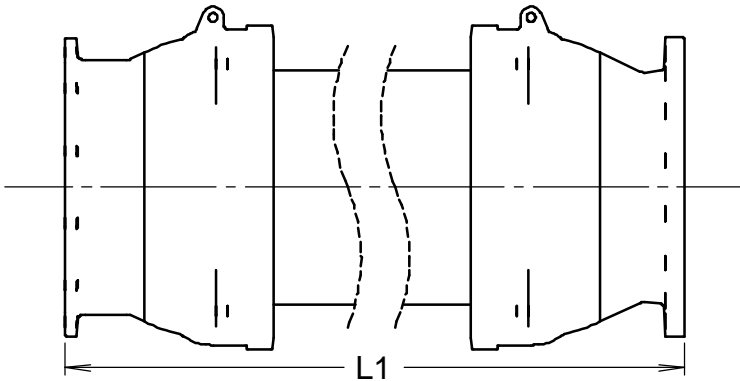
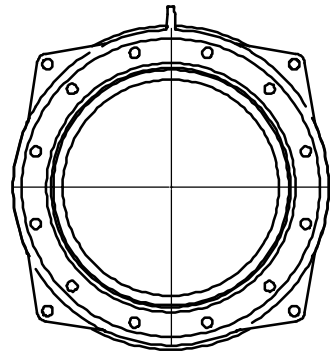

MJ X FLANGE

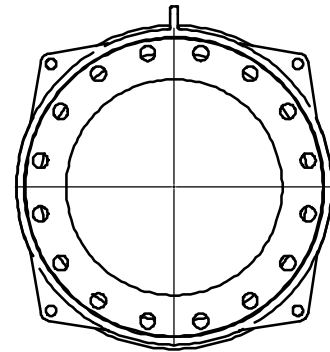

**NOTE:**  
 1. COMPLETE DIMENSION INFORMATION ON ROMAC DWG. B2121-C.

NOM. SIZE	OFFSET	L1		
		FLANGE X FLANGE	MJ X FLANGE	MJ X MJ
18"	4	49.0	48.7	48.5
	8	60.0	59.7	59.5
	12	74.0	73.7	73.4
	16	89.0	88.7	88.5
	20	104.0	103.7	103.5

UNLESS OTHERWISE SPECIFIED	SIGNATURES	DATE	
DIMENSIONS ARE IN INCHES	DRWN	'03 JAN 2	
TOLERANCES ARE ON:yes	CHECKED		
2 PL DECIMALS +/-	ENGRG		
3 PL DECIMALS +/-	ISSUED		

ROMAC IND. INC., SEATTLE, WA
TITLE FLEXIJOB, DOUBLE BALL, 18 MODELS

B2137-A	DOUBLE CLICK PIN FOR DXF		THIS DRAWING CONTAINS CONFIDENTIAL PROPRIETARY INFORMATION AND IS THE PROPERTY OF ROMAC IND. INC. IT IS TO BE USED ONLY FOR THE PURPOSE FOR WHICH IT IS SUBMITTED AND SHALL NOT HAVE ITS INFORMATION DISCLOSED OR REPRODUCED IN WHOLE OR IN PART FOR ANY PURPOSE WITHOUT PRIOR WRITTEN PERMISSION OF ROMAC IND. INC.
	SIZE A		SCALE 1 = 16

DWG. NO. B2137-A	REV. NO. -
SHEET 1 OF 1	