

FLANGE X FLANGE

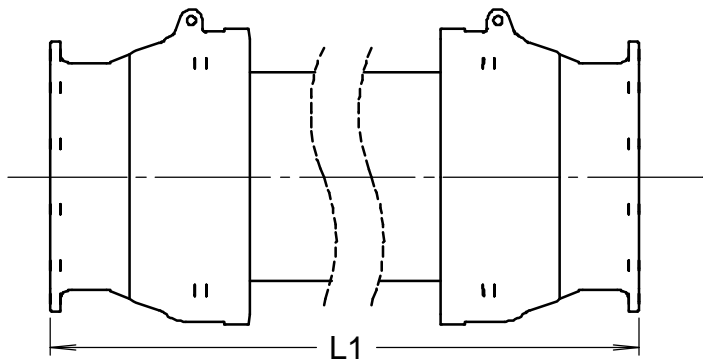

MJ X MJ

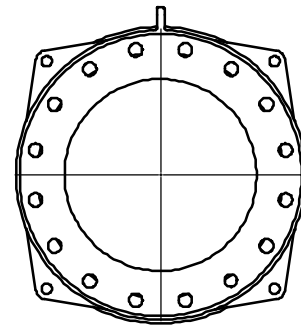
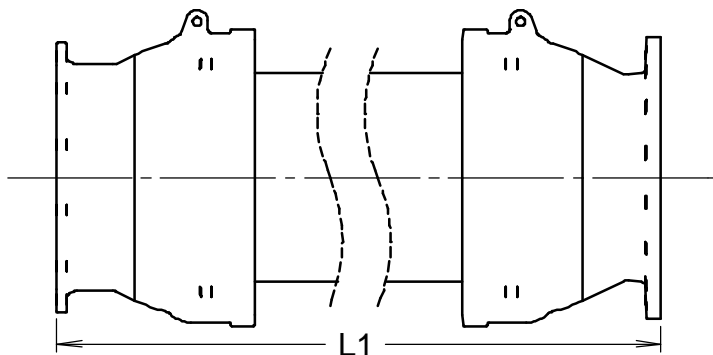
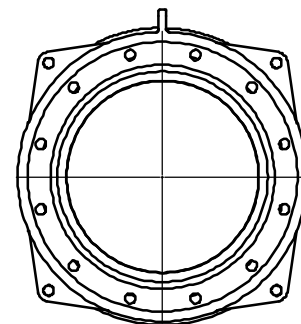

MJ X FLANGE

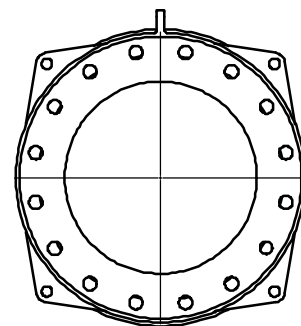

**NOTE:**  
1. COMPLETE DIMENSION INFORMATION ON ROMAC DWG. B2121-C.

NOM. SIZE	OFFSET	L1		
		FLANGE X FLANGE	MJ X FLANGE	MJ X MJ
16"	4	46.4	46.4	46.4
	8	57.4	57.4	57.4
	12	72.4	72.4	72.4
	16	87.4	87.4	87.4
	20	102.4	102.4	102.4

UNLESS OTHERWISE SPECIFIED	SIGNATURES	DATE	
DIMENSIONS ARE IN INCHES TOLERANCES ARE ON:yes 2 PL DECIMALS +/- 3 PL DECIMALS +/- ANGLES +/- FRACTIONS +/-	DRWN	'03 JAN 2	
	CHECKED		
	ENGRG		
	ISSUED		

ROMAC IND. INC.,  
SEATTLE, WA

TITLE  
FLEXIJOB, DOUBLE BALL, 16 MODELS

B2136-A	DOUBLE CLICK PIN FOR DXF		THIS DRAWING CONTAINS CONFIDENTIAL PROPRIETARY INFORMATION AND IS THE PROPERTY OF ROMAC IND. INC. IT IS TO BE USED ONLY FOR THE PURPOSE FOR WHICH IT IS SUBMITTED AND SHALL NOT HAVE ITS INFORMATION DISCLOSED OR REPRODUCED IN WHOLE OR IN PART FOR ANY PURPOSE WITHOUT PRIOR WRITTEN PERMISSION OF ROMAC IND. INC.	SIZE A	DWG. NO. B2136-A	REV. NO. -
			SCALE 1 = 16		SHEET 1 OF 1	